

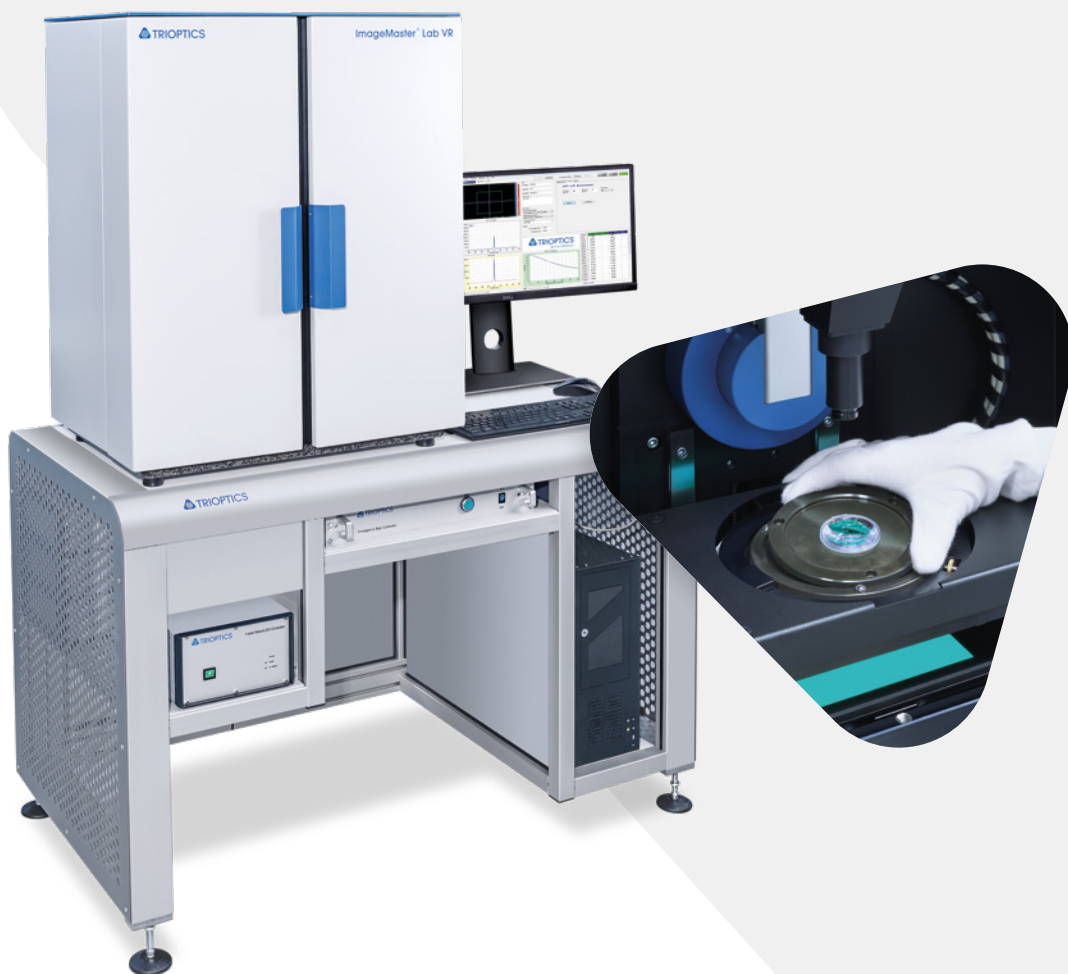

ImageMaster[®] Lab VR

A Measurement Device for
Testing VR Lenses and Modules



The ImageMaster® Lab VR was specifically developed for the measurement of VR lenses and VR module qualification. The system measures the MTF, EFL, chromatic aberration and distortion as well as the veiling glare index which is an important figure of merit of VR lenses.

A high contrast programmable display is used as a light source and object generator. The chromatic dependence of all parameters is determined by using the displays' individual color channels. For MTF measurements with highest accuracy an optional high intensity light source is available.

An automated eyebox simulates the lens behaviour in case the lens is not perfectly centered in front of the eye. Furthermore the eye's distance to the VR lens and the pupil diameter can be adjusted to the measurement task.

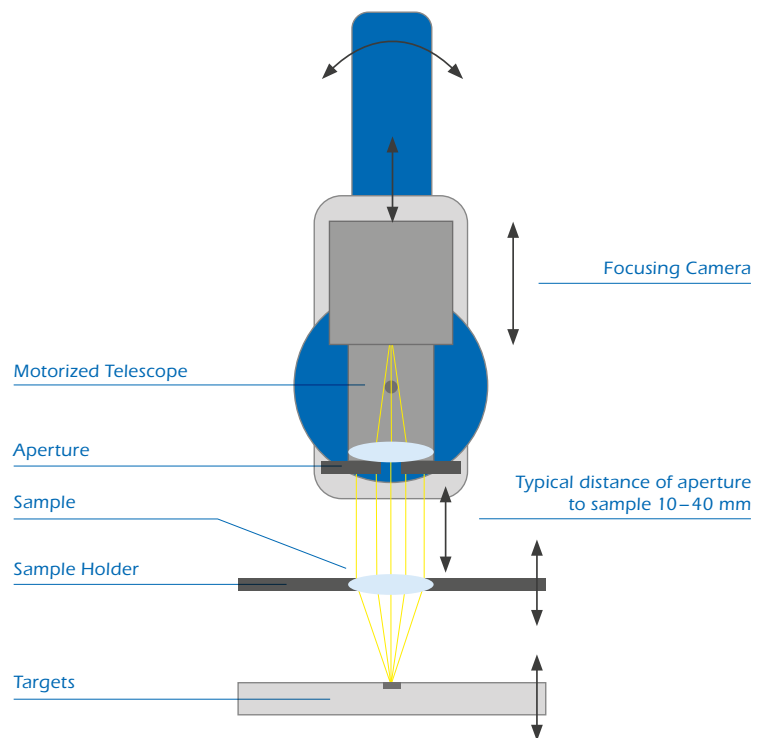

Key Features

- Simulation of human eye
- Measurement possible for various pupil distances and sizes
- Motorized telescope (+/- 2 dioptres)
- Eyebox Scanning
- Measurement possible for various wavelengths (RGB)
- Measurement with high-contrast, programmable display
- Integration of customer display possible
- Upgradeable to high intensity light source

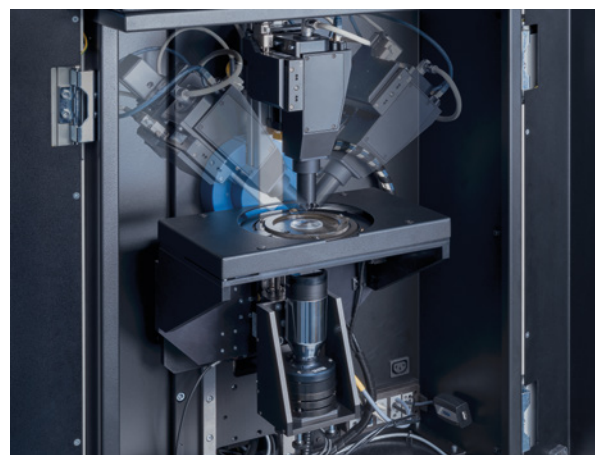

The swiveling telescope performs on and offaxis measurements simulating the rotational movement of the human eye over the entire field of view supporting +/-90°.

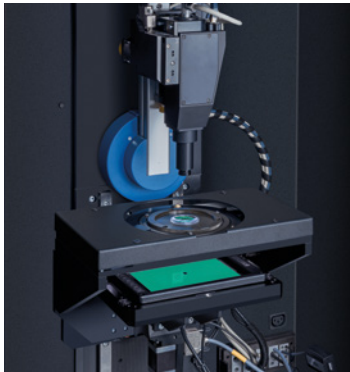

The display can optionally be exchanged for a customer display. The measurement with display is the first choice for veiling glare measurements.

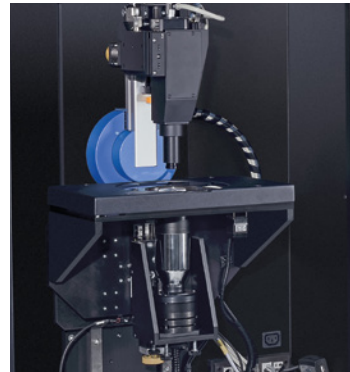

The high intensity light source is easily exchangeable and determines the MTF with reticle which gives the highest measurement accuracy.

Measurement Parameters

- MTF
- EFL
- Veiling Glare Index (only with Display)
- Distortion
- Chromatic Abberation
- Focus distance, virtual image position

Software MTF-Lab

- Scripting tools for customer-specific programming and analysis
- Functions for easy alignment of the sample
- Intuitive user interface and time-saving lens testing routines
- Certificate output in HTML format, can be imported to MS Excel
- Target Generator

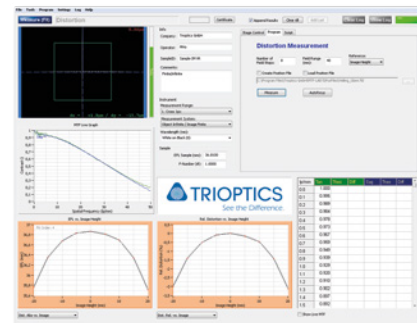

Technical Data

	Veiling Glare Index (according to ISO 9358)		MTF		Distortion	EFL
	Display	RET	Display	RET		
Measuring accuracy	< ± 5 %	—	+/- 2 %	+/- 1 %	± 0.25 %	± 0.2 %
Repeatability	< ± 3 %	—	± 1 %		± 0.1 %	± 0.2 %

Sample Range for Single Lenses

Effective focal length (EFL)	Max. flange focal length (FFL)	Max. Image Height	Sample diameter	Max. weight *
10–80 mm	50 mm	± 35 mm	< 70 mm	2 kg

* max. weight VR modules: 2 kg



TRIOPTICS GmbH

Strandbaddamm 6
22880 Wedel
Germany

+49 4103 18006-0
sales@trioptics.com
www.trioptics.com

